

Installation, Operation, and Maintenance Manual

API 594 Dual Plate Wafer Check Valve

DPWC Series

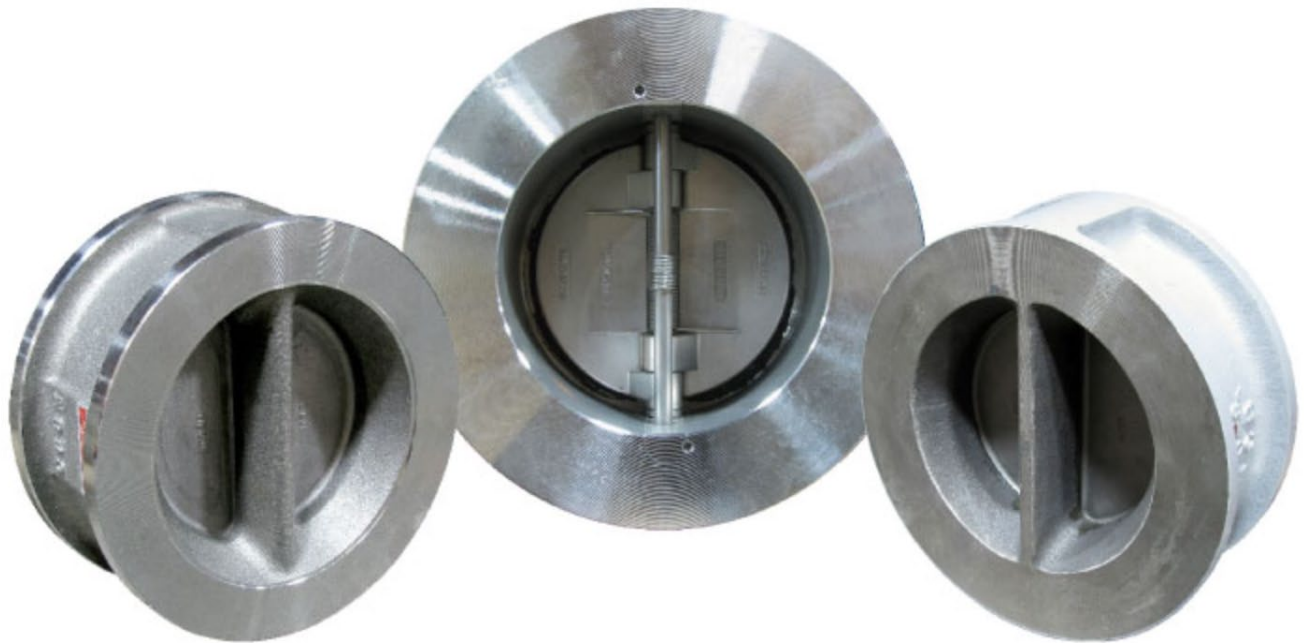



Table of Contents

1	INTRODUCTION.....	3
1.1	SCOPE.....	3
1.2	DISCLAIMER.....	3
1.3	SAFETY INFORMATION.....	3
2	VALVE INFORMATION.....	4
2.1	NAMEPLATE.....	4
2.2	VALVE MARKING.....	5
2.3	BILL OF MATERIALS.....	6
3	RECEIVING, HANDLING AND STORAGE.....	7
3.1	RECEIVING AND HANDLING.....	7
3.2	STORAGE.....	7
4	INSTALLATION.....	8
4.1	GENERAL INFORMATION.....	8
4.2	INSTALLATION GUIDELINES & INSIGHTS.....	8
4.3	TECHNICAL GUIDELINES PRIOR TO INSTALLATION.....	10
4.4	HORIZONTAL INSTALLATION.....	10
4.5	VERTICAL INSTALLATION.....	11
5	OPERATION.....	11
5.1	NORMAL OPERATION ACTIVITY.....	11
5.2	HIGH TEMPERATURE SERVICE.....	11
6	MAINTENANCE.....	12
6.1	DISASSEMBLY.....	13
6.2	RECONDITIONING.....	14
6.3	RE-ASSEMBLY.....	15
7	PROPER VALVE TESTING.....	15
8	TROUBLESHOOTING.....	16

1 INTRODUCTION

1.1 SCOPE

The C&C DPWC Series is an API 594 Dual plate wafer check valve designed to automatically prevent back-flow in systems where it is desirable to permit flow in one direction and prevent flow in the opposite direction. When the pump starts and the downstream flow creates the required pressure drop in the forward direction, the Dual Plates will automatically open. When the pump stops and the flow ceases, the torsion of the spring will automatically close the Dual Plates prior to flow reversal. This creates a positive shutoff against flow reversal and eliminates system surges and water hammer.

The following information is intended for the proper installation, operation, and maintenance of C&C's DPWC Series.

1.2 DISCLAIMER

When properly operated, maintained, and installed in applications suitable to the materials of construction, C&C's DPWC Series dual plate wafer check valves will provide long and trouble-free service. The **End User** is responsible for ordering the correct valve(s) and operating the valve(s) in observance of the valve's pressure rating and temperature limits. Prior to installation, the valve and valve's nameplate should be checked for proper identification to ensure the valve is of proper type, material(s) and is of a suitable pressure class, service media compatibility and temperature limit to satisfy the application requirements.



The **End User** is advised that misapplication of the product may result in injuries, death and/or property damage.

1.3 SAFETY INFORMATION



We **highly recommend** that this entire document be read prior to proceeding with any installation, operation, or maintenance.

Due to the hazardous nature of pressurized piping systems, it is recommended the following precautions and guidelines, at a minimum, must be followed to minimize hazards related to pressurized piping systems:

- (a) The End User is responsible for meeting state, local, and all applicable national safety practices and codes.
- (b) The End User is responsible for minimizing other hazards associated with the installation, operation, and maintenance of pressurized piping systems.
- (c) The valve's nameplate indicates the materials of construction and maximum operating pressure at maximum and minimum operating temperatures. The valve can be safely operated within these limits.

(d) The End User is responsible to select valve material based on the service media. Contact CNC Flow Control to confirm whether valve design is suitable for the application. CNC Flow Control requires a complete description of the application before making any recommendation.



Do **not** operate any valve beyond the pressure and temperature limits stated on the valve's nameplate.

2 VALVE INFORMATION

2.1 NAMEPLATE

Each C&C DPWC Series dual plate wafer check valves is equipped with an identification nameplate placed on the valve's cover. The following is an example of the nameplate containing the valve's pertinent data.

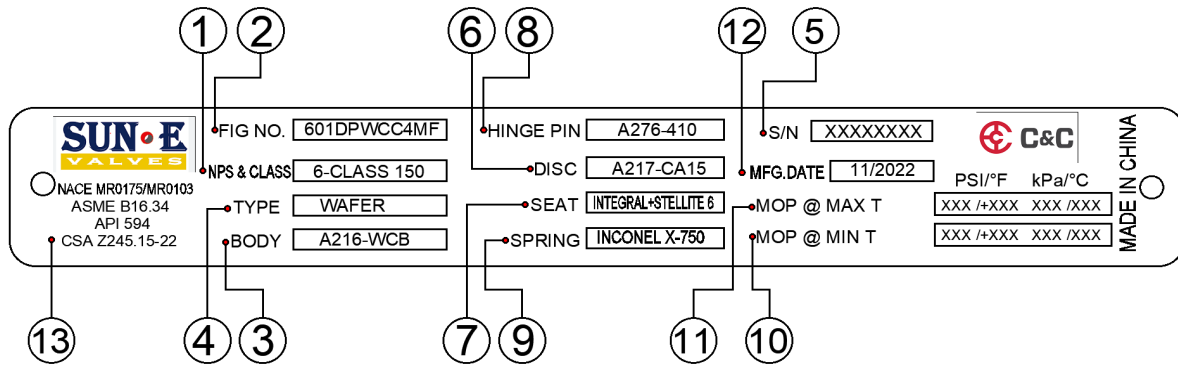

Figure 1: C&C DPWC Series dual plate wafer check valve's nameplate

Table 1: Valve nameplate information

Item	Description	Item	Description
1	Nominal Pipe Size & Pressure Class	8	Hinge Pin Material
2	Figure Number	9	Spring Material
3	Body Material	10	Maximum Pressure at Minimum Temperature
4	Valve Type	11	Maximum Pressure at Maximum Temperature
5	Serial Number	12	Manufactured Date
6	Disc Material	13	Valve Design (Pressure & thickness)
7	Seat Material		

2.2 VALVE MARKING

Figure 2: C&C DPWC dual plate wafer check valves body marking and nameplate placement.

2.3 BILL OF MATERIALS

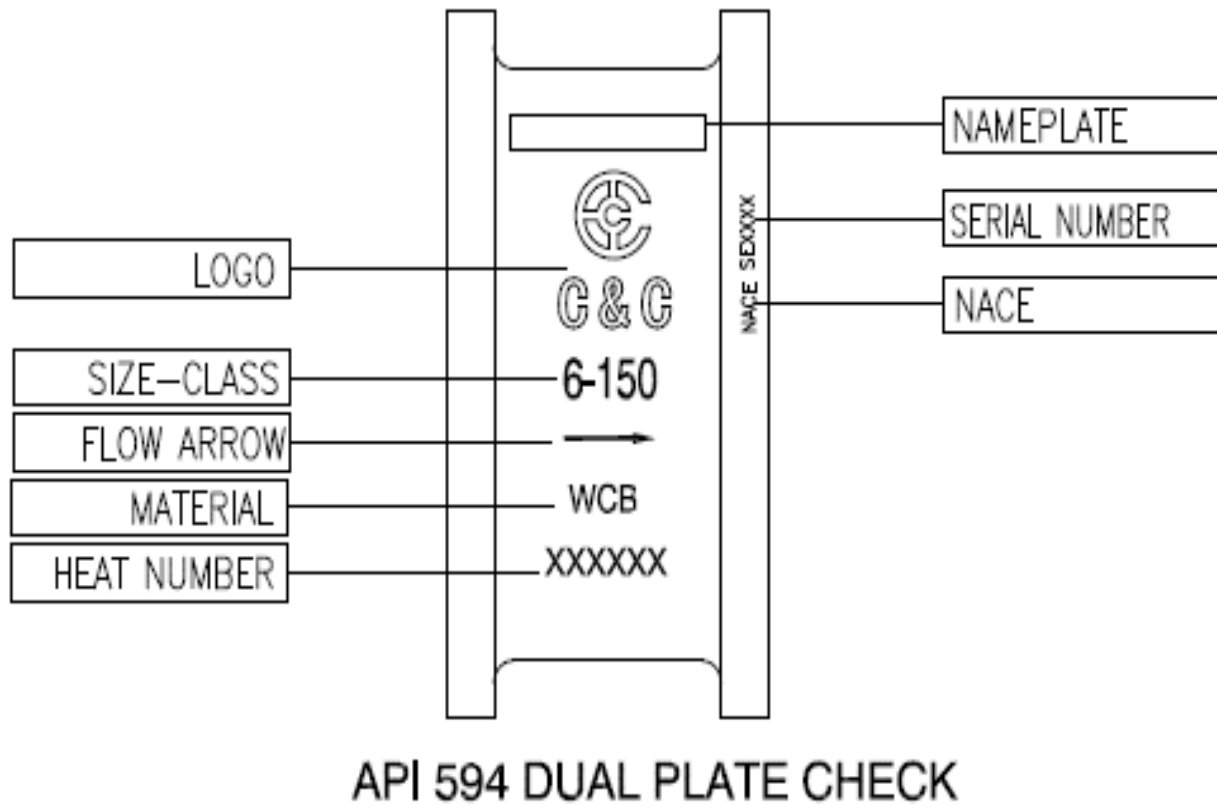
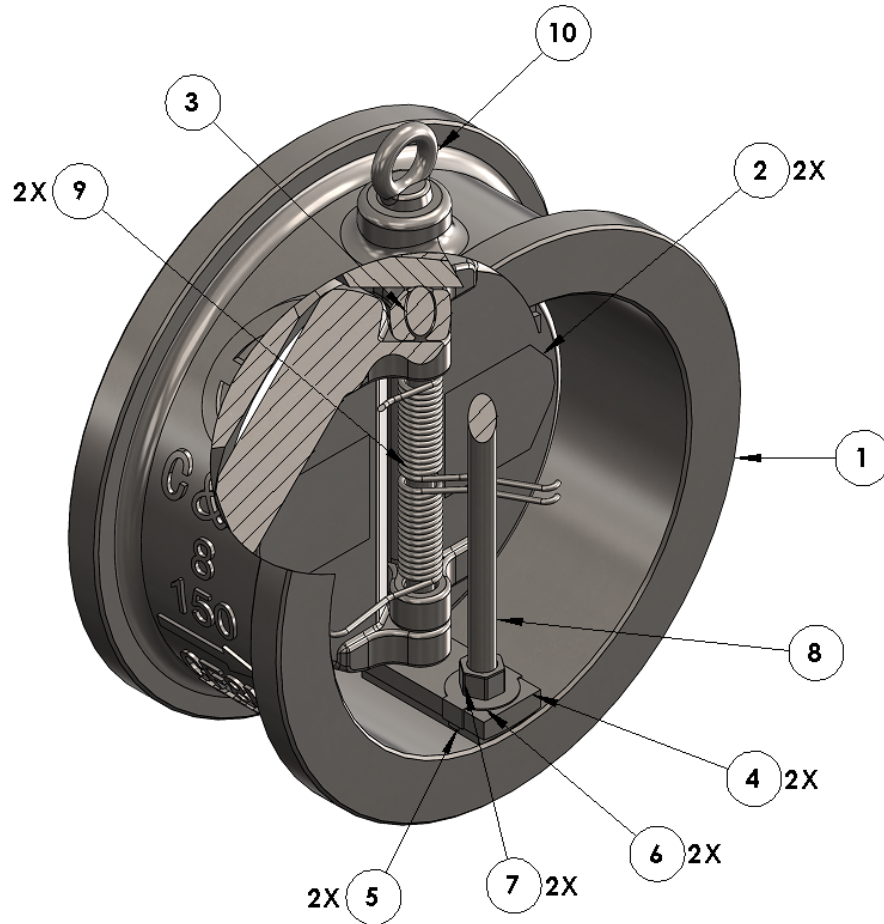

Figure 3: C&C DPWC Series dual plate wafer check valve View

Table 2: DPWC Series Bill of materials

Item	Qty	Name	Material	Specification
1	1	Body	For materials of construction and material specification refer to the corresponding valve Sales drawing	
2	2	Disc		
3	1	Hinge Pin		
4	2	Holder		
5	2	Key		
6	2	Clip		
7	2	Nut		
8	1	Stop Pin		
9	2	Spring		
10	1	Eye Bolt		
**	*	Washer		
<p>* - Quantities as required ** - Size 16" and higher.</p>				

3 RECEIVING, HANDLING AND STORAGE

3.1 RECEIVING AND HANDLING

Valves should be inspected upon receipt to determine:

- Packaging integrity
- Compliance to the purchase order
- Correct type, pressure class, size, body & trim material, and quantity
- Damage caused during shipping and handling to the valve or flange end connections.

Any damage noticed during receiving inspection should be evaluated to determine its severity and to implement repairs if possible. Severe damage to the valve should be reported to CNC Flow Control.



If the valve's flange protectors are found to be missing or damaged, an inspection of the valve's flow bore/cavity is required to remove any foreign material that may have entered the valve.

Lifting shall be done with slings, straps or hooks using valve body. The C&C DPWC Series dual plate wafer check valve is supplied with lifting eyebolt for size 6" 600# and larger attached to the body externally to facilitate removal during repair. **Only** lifting devices that are rated for the valve weight shall be used when lifting any C&C valves.



The **End User** is advised to follow all applicable industry recommendations when lifting the valve. Failure to follow good practices may result in injuries, death and/or property damage.

3.2 STORAGE

Valves received in their original shipping containers may be stored for up to a year provided they are stored indoors and not exposed to extreme temperatures, contamination by dirt or high humidity. C&C DPWC Series dual plate wafer check valves are shipped with flange end protectors which should remain installed until the valves are ready to be installed. If valves are to be stored inside for more than a year, a desiccant may be required, and it is also recommended that a periodic inspection of the valve be performed to ensure proper storage and valve condition.



Non-observance of crate handling markings **could** result in serious injury of people and damage to the goods.



If the valve is removed from its original shipping container or stored outdoors, the **End User** must ensure that the valve is adequately protected to prevent valve damage or contamination.

4 INSTALLATION

4.1 GENERAL INFORMATION

C&C's DPWC Series dual plate wafer check valves are 100% tested at the factory per API 598 and shipped ready for installation. Consider the following points before installation:

- Experienced and trained personnel should install this valve.
- State, local, and all applicable national safety practices and codes relating to valve or pressurized equipment installation should be followed.
- Inspect valve documentation, nameplate, and body markings to ensure that the correct valve is installed.
- Inspect the entire valve for damage prior to installation.
- Inspect the flange sealing surface for dents or scratches that may affect sealing.
- Remove flange end protectors prior to installation.

4.2 INSTALLATION GUIDELINES & INSIGHTS

- Observe the valve **flow directional arrow** for guidance on proper orientation. The valve must be installed with the flow line in the same direction as the flow directional arrow present on the valve's body.



Failure to correctly match the flow directional arrow with the pipeline flow direction will result in undesired valve operation.

- Thoroughly clean the adjacent piping system to remove foreign material that may cause damage to the valves sealing surface.
- Verify that the space available for installation is adequate to allow the valve to be installed and serviced in line if so desired.
- While supporting the existing pipeline, lift the Check Valve into position.
- For large or heavy Check Valves, the appropriate material handling equipment must be used to prevent injury and possible damage to the Check Valve.
- When lifting the Check Valve, utilize the eye bolt (See Fig.4) or place slings/ chains securely around the valve body. (See Fig.5)



Never lift the Check Valve by attaching slings/chains to the **trim/seat** assembly. The trim/seat assembly is not designed to withstand the weight of the unit. (See Fig.4)

- To avoid leakage between the check valve and mating flanges, a 1/8" THK. Gasket per ANSI B16.5 is recommended.

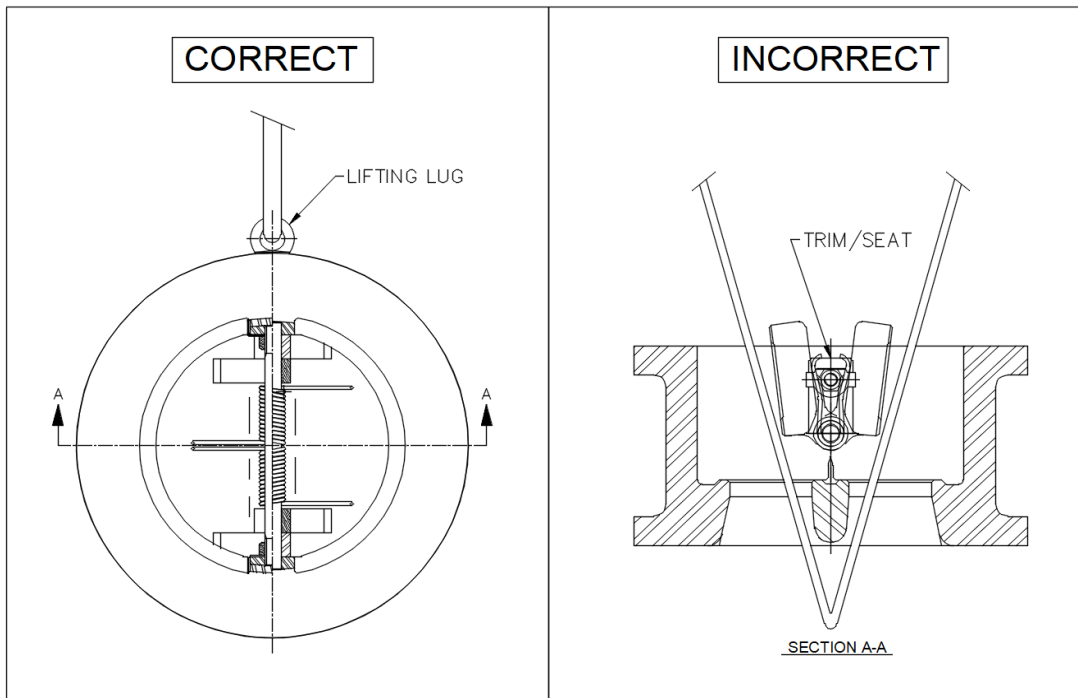

Figure 4: C&C DPWC Series dual plate wafer check valve proper lifting with lifting lug

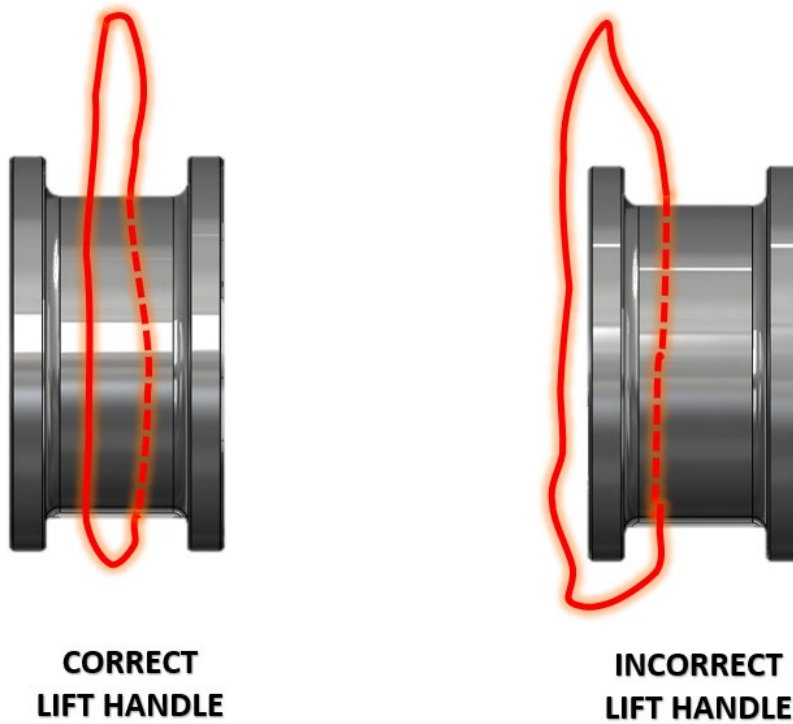

Figure 5: C&C DPWC Series dual plate wafer check valve lift handle w/o lifting lug

4.3 TECHNICAL GUIDELINES PRIOR TO INSTALLATION

- It's recommended to install check valves 6 to 10 pipe diameters for effective operation and extended service life from any turbulence-producing equipment (swages, expansions, reductions, tees, pumps, and elbows).
- Reciprocal pumps and compressors can cause pressure surges and vibrations in the pipe system. **It's crucial to install everything appropriately.** To lessen the chance of water hammer, which can occur in systems with reciprocating pumps, factors such as flow rates, pressure fluctuations, and the type of fluid being handled should all be considered when selecting and installing check valves in proximity to compressors or reciprocating pumps. Additional important considerations include the direction of the check valve and the availability of adequate anchoring and support.
- C&C's DPWC Series **can only be mated** with **Flat-Faced** pipe flanges per ANSI 16.5.

4.4 HORIZONTAL INSTALLATION

All C&C DPWC Series dual plate wafer check valves shall be installed in the horizontal position with the body marking upright and arrow mark on the body pointing in the direction of flow. Eyebolt hinge pin must be vertical and can be used to correctly position the valve.



CORRECT



INCORRECT



The valve **shall not** be installed horizontally with the body marking and arrow pointing downward from the vertical position.

4.5 VERTICAL INSTALLATION

- When installing the C&C DPWC Series dual plate wafer check valves in a vertical pipeline, the valve must be installed horizontally with flow arrow pointing upwards and **properly oriented** to ensure equal loading on the Dual Plates. The graphic below illustrates this. The weight of the discs should be expected to cause additional pressure drop.
- Orient the flow arrow (cast into the side of the valve body) in the direction of the pipeline flow. When the dual plates are in the proper position, they will travel away from the valve seat in the direction of the pipeline flow.

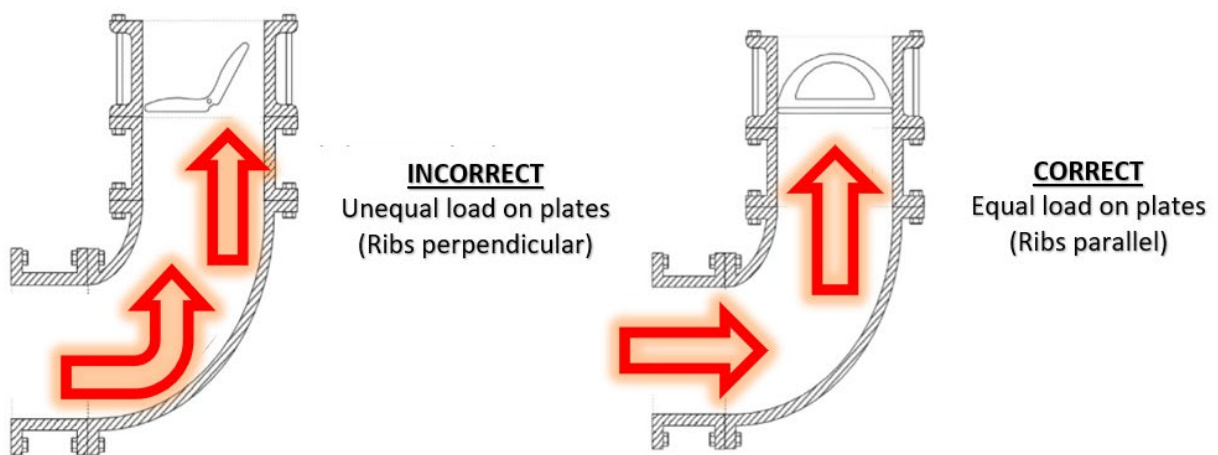

Valve **can only be installed** with flow direction upward. In the vertical position, the outlet will be above the inlet.

5 OPERATION

5.1 NORMAL OPERATION ACTIVITY

After installing the C&C's DPWC Series dual plate wafer check valve properly, start the system gradually, both at startup and after shutdown. This prevents the Check Valve and other equipment in the line from being shocked.

5.2 HIGH TEMPERATURE SERVICE

Some applications have operating temperatures that can be very dangerous to people or animals. To avoid any kind of injuries operators must ensure the valve surfaces that reach such temperatures are suitably protected against accidental contact. Operators are recommended to always provide efficient protection/insulation of the valve surfaces that may be touched by personnel and/or animals and that are beyond tolerable limits.

6 MAINTENANCE

The C&C's DPWC Series dual plate wafer check valve requires little to no attention during operation and is designed to ensure trouble-free service with minimal maintenance. The valve is a self-contained unit responding automatically to pipeline flow. During inline maintenance, the valve must be isolated in the pipeline and depressurized.



Depressurization and isolation **must** be done from associated piping system equipment both upstream and downstream to the valve.

As with all pressurized equipment, proper PPE should be worn when preparing to service the valve. Observe the following general warning before disassembly begins.



- A valve is a pressurized device containing energized fluids and should be handled with extreme care.
- Depending on the operating condition, the valve's surface temperature may be dangerously hot or cold.
- Depending on the process fluid, the valve may be required to be decontaminated or flushed before any maintenance can begin. *Please review MSDS for specific fluid*
- Upon disassembly, attention should be paid to the possibility of releasing dangerous and/or ignitable service media.

Once the valve is depressurized and allowed to cool, if applicable, disassembly may begin. To disassemble the C&C's DPWC Series dual plate wafer check valve, follow the steps below. **Refer to Figure 6.**

6.1 DISASSEMBLY

Figure 6: C&C DPWC Series dual plate wafer check valve exploded view.

Table 3: DPWC Series bill of materials

Item	Qty	Name
1	1	Body
2	2	Disc
3	1	Hinge Pin
4	2	Holder
5	2	Key
6	2	Clip
7	2	Nut
8	1	Stop Pin
9	2	Spring
10	1	Eye Bolt
**	*	Washer (16" and higher)

1. It is recommended that the valves be placed down on a board to protect the flange face, with the arrow facing **upward**, so that the valve internals can be disassembled with less difficulty.
2. Unscrew top/bottom nut (7) and remove clips (6) by sliding them to the center of the pin.

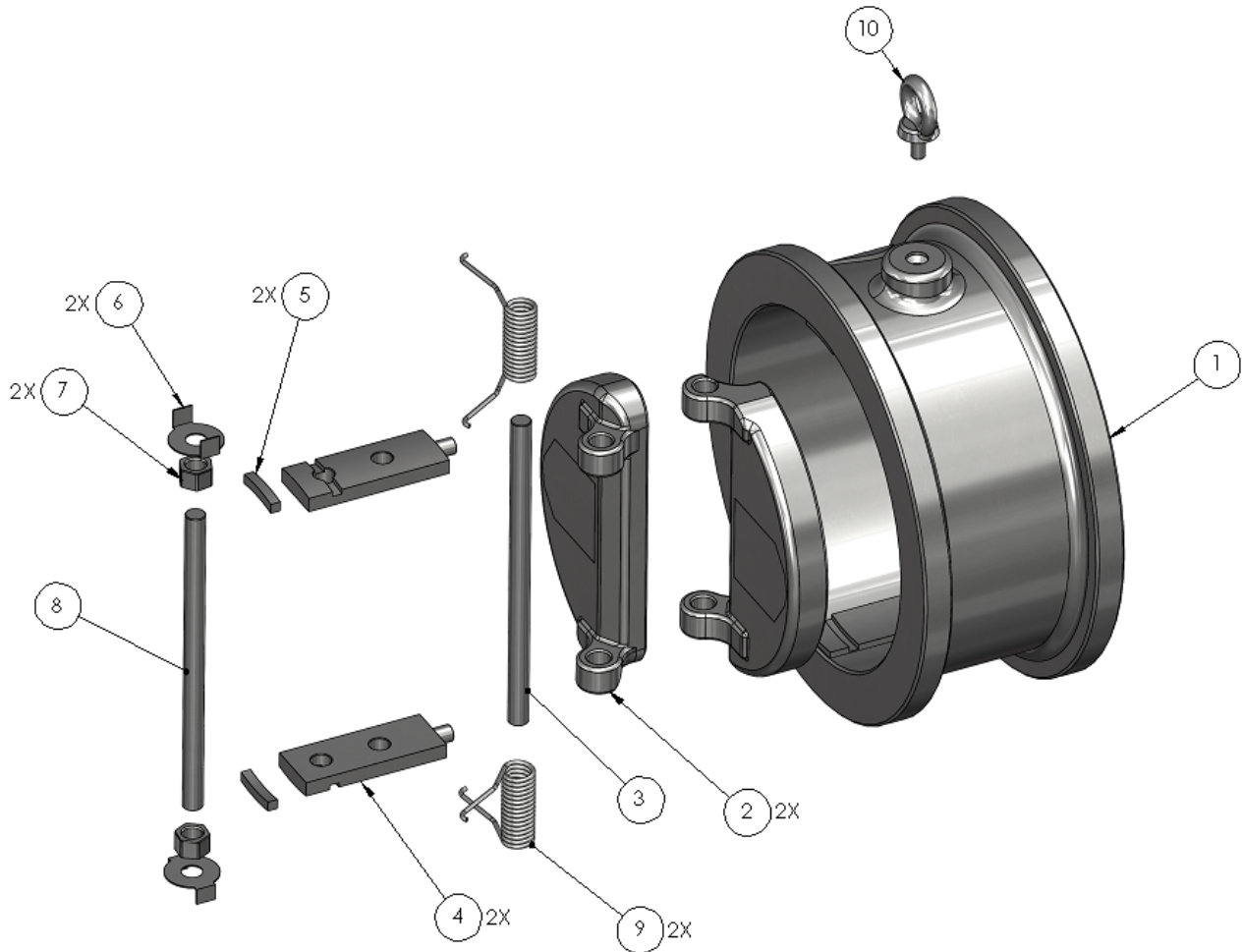
NOTE: Only 8” valves and larger have nut.



Use Valve cleaner to break up any encrusted residue and remove any debris or additional grease with a cloth for easier access as the dismantle process proceeds.

3. Carefully remove the top/bottom keys (5); the stop pin (8) can be pulled using a pair of pliers, keep in mind all other components will also be pulled out during this operation.
4. Once stop pin (8) has been removed, the holders (4) will have attached springs (9), hinge pin (3), and discs (2); both disc seating surface will be facing downward upon removal.
5. Sort and arrange the components into separate sections. To protect sealing surfaces, place the disc seating surface face down on a piece of fabric or cardboard.
6. Inspect the body (1) seating surface for damage.

6.2 RECONDITIONING



Contact CNC Flow Control for replacement of damaged parts. Valve reconditioning repair kits are available.



Any type of reconditioning or repair work must be performed by a qualified technician.

Once the valve is disassembled, clean and inspect all components to ensure that the valve functions properly once reassembled. Consider the following points before reassembly:

- Before repairing the valve, check all components for nicks, pinches, wear & tear.
- It is recommended to clean metal (ex. Pins) parts using appropriate cloths & valve cleaner.
- After components have been inspected and cleaned, a thorough inspection of sealing areas for scores or damage is required; if damage is found in sealing areas, it is critical to contact CNC (valve manufacture) for further assistance.
- Lubricate components with appropriate sealer.
- On rotational metal surfaces it's appropriate to use sealants to break hardened areas and lubricants for maintenance.

6.3 RE-ASSEMBLY

To re-assemble the C&C DPWC Series dual plate wafer check valve, follow the steps below.

Refer to **Figure 6**

1. Align both discs (2) by placing their hinge slots on top of each other.
2. Place springs (9) between the hinge slots before sliding hinge pin (3) between discs (2) hinge slots to keep the springs in place. **NOTE:** To protect the seats from opening/engaging, the spring end tails must be put towards the seats (2).
3. Place the slide nuts (7) and clips (6) in the middle of the stop pin (8).
4. Begin with the bottom holder (4) and attach the hinge pin (3) and stop pin (8) with components. Place the top holder (4) on top of the bottom holder to keep the components from falling apart.
5. Slide the holders (4) and the remaining components into the body cavity holes. If necessary, use a mallet hammer to slide components inside.
6. Reinstall the keys (5) and clips (6) on both sides.
7. Tighten nut (7) on both sides. **NOTE:** Only 8” valves and larger have nut.
8. For valves with eye bolt (10), remove if necessary and reinstall after inspecting threads. Use Loctite to ensure a tight seal.

7 PROPER VALVE TESTING

Always perform an API 598 pressure test before re-installing the valve into the line to verify that the maintenance operation has been satisfactorily performed and to re-certify pressure containment capability of the valve. Testing shall only be performed by qualified personnel.



Installing the valve in the line without pressure testing could cause leakage of production media and a potentially hazardous situation.

Owner to follow code of construction (Ex. ASME B16.34 or B31.3) if repair/ added Check Valve on a pressure piping system. For component to be leak tested within piping system and avoid future leakage.

8 TROUBLESHOOTING

Issue	Possible Cause	Solution
Leakage at the end flanges	<ol style="list-style-type: none"> 1. Flange bolt torque 2. Gaskets damage 3. Seating surface damage 	<ol style="list-style-type: none"> 1. Check and tighten end flanges per ASME B16.5 2. Remove and inspect connection Gaskets. Replace if necessary 3. Inspect flange ends surface and check for damage.
Back flow (Leakage past Seats)	<ol style="list-style-type: none"> 1. Spring damage 2. Seating surface damage 3. Seat or pin damage 	<ol style="list-style-type: none"> 1. Remove and inspect springs. Replace component(s) as necessary 2. Inspect body seating surface and check for damage. Contact CNC Flow Control if damage found. 3. Remove Seats and pins. Inspect both components for any damage. Replace component(s) as necessary.
No flow through valve	<ol style="list-style-type: none"> 1. Incorrect valve placement 	<ol style="list-style-type: none"> 1. Ensure that the valve is installed with the flow direction in the same direction and the pipeline flow direction

Table 4: C&C DPWC Series recommended solution for possible issues.

Note: Contact CNC Flow Control if you experience issues not covered in this section & for replacement parts and Valve repair kits.



CNC Flow Control
10350 Clay Road, Suite 250
Houston, Texas 77041

Toll-free: (844) 398-6449
Phone: (713) 466-1644
Fax: (713) 466-1715
Website: www.cncflowcontrol.com

This manual is provided for informational purposes only and is solely intended for the installation, operation, and maintenance of CNC Flow Control DPWC Series API 594 dual plate wafer check valves. CNC Flow Control reserves the right to change information contained in this manual without any notice. Contact CNC Flow Control at the above address for specific questions regarding this manual or valve.

Although this manual has been checked for accuracy, the **Purchaser** or **End User** is ultimately responsible for the correct installation, operation, and maintenance of any valve in their pipeline. Therefore, information contained in this manual shall not be construed as a guarantee or product warranty.